

i100 ELITE SR4

LPCB CERTIFIED STEEL SECURITY SHUTTER :: TECHNICAL DATASHEET 30

ROCHÉ



Our most secure shutter. The i100 Elite SR4 has been tested by the Loss Prevention Certification Board to LPS1175 (7.0), achieving an SR4 rating for resistance to attack. It also meets the 'Secured by Design' criteria and is insurance approved. This is achieved through special security features including a bullet locking system.



LPS 1175: Issue 6
Cert/LPCB ref: 931b/06



APPLICATIONS

Very high security public, commercial & industrial sites. The i100 Elite has been tested by the Loss Prevention Certification Board LPS1175 (7.0), rated SR4, and awarded 'Secured by Design' status. Suitable for internal face fix installation only.

LOCKING MECHANISMS

The i100 incorporates a bullet locking system situated approx. 1m from ground level, fixed to each guide channel; central ground anchor on the bottom lath on shutters over 3 metres wide.

CURTAIN SLAT

Double skin mild steel slat with 81mm face. Wall thickness 1.2mm.

Finish: Galvanised finish as standard. Option to powder coat any RAL / BS colour or to choose from a range of plastisol finishes (surcharges apply).

| | |
|-----------------------------|--|
| Visible Face: | 81mm |
| Weight per m ² : | 100kg |
| Maximum Width: | 3000mm |
| Maximum Area: | 4m ² (tubular) 35m ² (outboard) |

CASING

Galvanised steel casing & end plates as standard. Optional fascia / custom design casings available on request (surcharge applies).

Finish: Galvanised finish as standard. Option to powder coat any RAL / BS colour (surcharge applies).

| Guide Height (mm) | Plate Size (mm) |
|-------------------|-----------------|
| 1750 | 400 |
| 2500 | 450 |
| 3250 | 500 |
| 4000 | 550 |
| 5000 | 600 |

Plate sizes shown as a guide only and may vary. Note that outboard motors are generally larger than the plate itself.

BOTTOM RAIL

Galvanised steel bottom rail with rubber weather seal.

GUIDE CHANNELS

85mm wind guides as standard.

OPERATION

Electric, Tubular Motor: Tubular motor with internal rocker or external key switch as standard with safety brake as appropriate to comply with legislation. Manual override facility & crank handle as required (surcharge applies).

Electric, Outboard Motor: Three phase motors with safety brake, chain manual override & TS959 push button control station as standard.

Both tubular & outboard motors have numerous control option variants such as group, remote or mobile phone activation.

CE compliant to all applicable directives and regulations.

i100 ELITE SR4

LPCB CERTIFIED STEEL SECURITY SHUTTER :: TECHNICAL DATASHEET 30



FRONT FACE & FIXING DETAIL

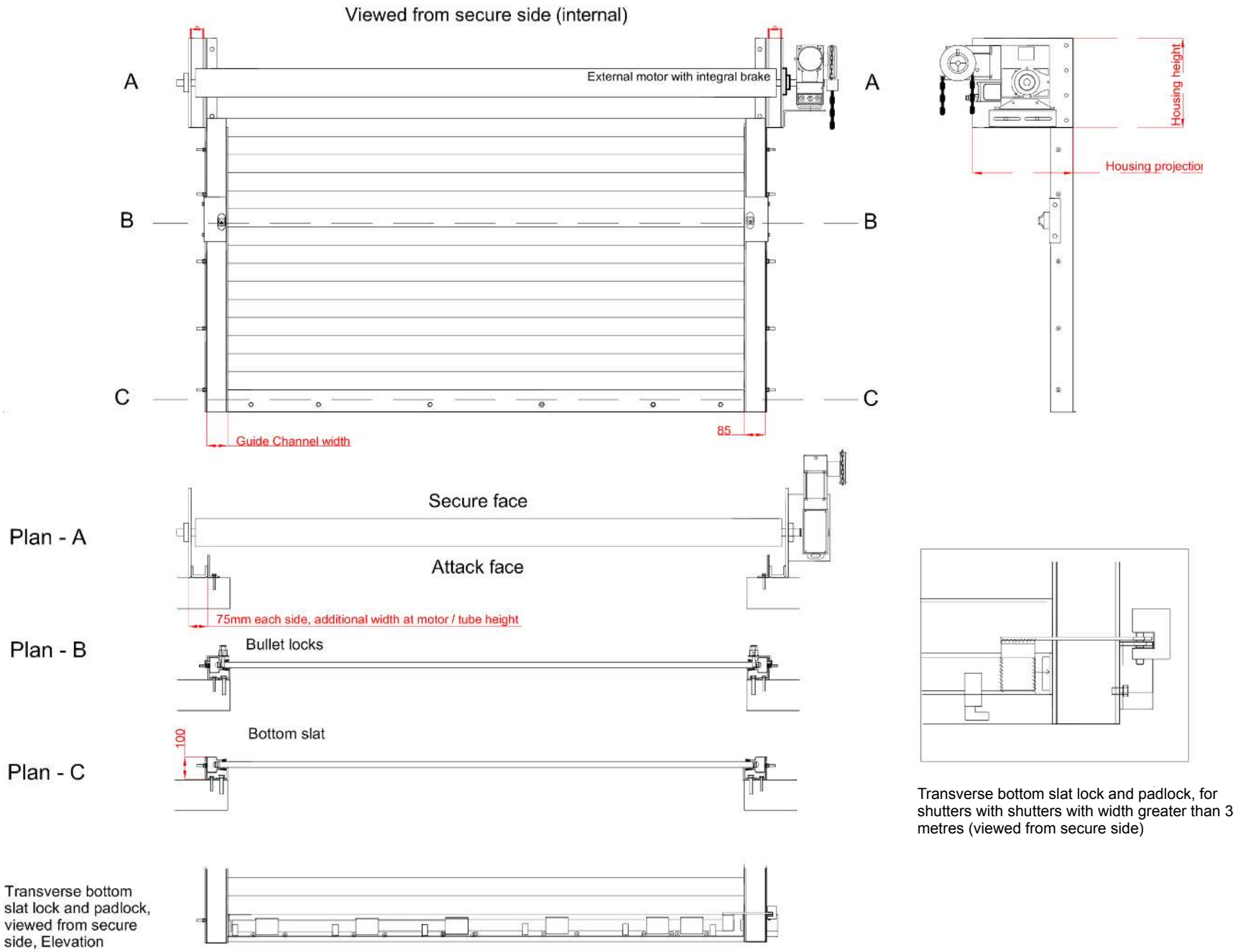

SLAT PROFILE

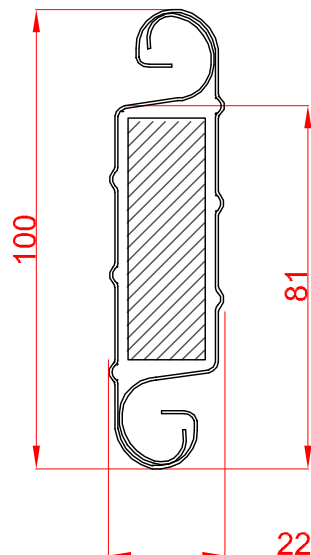

GUIDE CHANNELS

